

A Locus for an Axonal Form of Autosomal Recessive Charcot-Marie-Tooth Disease Maps to Chromosome 1q21.2-q21.3

Ahmed Bouhouche,^{1,2} Ali Benomar,² Nazha Birouk,² Angélique Mularoni,³ Farid Meggouh,² Johann Tassin,¹ Djamel Grid,⁴ Antoon Vandenberghe,³ Mohamed Yahyaoui,² Taïeb Chkili,² Alexis Brice,¹ and Eric LeGuern¹

¹INSERM U.289, Fédération de Neurologie, Hôpital de la Salpêtrière, Bâtiment Nouvelle Pharmacie, Paris; ²Laboratoire de Neurogénétique et Laboratoire de Neurophysiologie, Service de Neurologie, Hôpital des Spécialités, Rabat-Instituts, Rabat, Morocco; ³Laboratoire de Génétique Moléculaire Humaine, Université Claude Bernard, Lyon; and ⁴Association Française contre les Myopathies, Evry, France

Summary

Charcot-Marie-Tooth disease (CMT) is a heterogeneous group of disorders that affect the peripheral nervous system. Three loci are known for the autosomal dominant forms of axonal CMT (CMT2), but none have yet been identified for autosomal recessive axonal CMT (ARCMT2). We have studied a large consanguineous Moroccan ARCMT2 family with nine affected sibs. The onset of CMT was in the 2d decade in all affected individuals who presented with a severe motor and sensory neuropathy, with proximal muscle involvement occurring in some patients. After exclusion of known loci for CMT2 and for demyelinating ARCMT2, a genomewide search was performed. Evidence for linkage was found with markers on chromosome 1q. The maximum pairwise LOD score was above the threshold value of 3.00, for markers D1S514, D1S2715, D1S2777, and D1S2721, and it reached 6.10 at the loci D1S2777, D1S2721, and D1S2624, according to multipoint LOD-score analysis. These markers defined a region of homozygosity that placed the gene in a 4.4-cM interval. Moreover, a recombination event detected in an unaffected 48-year-old individual excludes the D1S506 marker, thereby reducing the interval to 1.7 cM. In addition, the P0 gene, an attractive candidate because of both its location on chromosome 1q and its role in myelin structure, was excluded by physical mapping and direct sequencing.

Introduction

Charcot-Marie-Tooth disease (CMT; MIM 118200), the most common hereditary motor and sensory neuropathy, is known to be a clinically, electrophysiologically, neuropathologically, and genetically heterogeneous group of disorders that affect the peripheral nervous system. Advances in molecular genetics have contributed to our understanding of both the pathogenesis of CMT and the classification of its forms on the basis of electrophysiological, morphological, and genetic criteria (Gabreëls-Festen et al. 1993). However, the autosomal recessive forms of CMT are still poorly documented. Four loci have been identified for demyelinating forms of the disease (Ben Othmane et al. 1993; Bolino et al. 1996; Kalaydjieva et al. 1996; LeGuern et al. 1996), but the corresponding genes are not yet known.

To date, no locus has been associated with autosomal recessive axonal forms of CMT (ARCMT2), because of the apparent rarity of these forms. Indeed, only a few families with established consanguinity have been reported. In these families, the disease was found to be both more severe and earlier in onset than autosomal dominant axonal CMT (Harding and Thomas 1980; Ouvrier et al. 1981; Gabreëls-Festen et al. 1991). In northern Africa, consanguineous marriages are common, and autosomal recessive traits, including ARCMT2, are frequent. In the present study, we performed a genomewide search in a large consanguineous Moroccan family presenting with ARCMT2. We found evidence for linkage to chromosome 1q21.2-q21.3.

Family and Methods

Family

A large consanguineous family of Moroccan ancestry was examined in the Service de Neurologie of the Hôpital des Spécialités, Rabats-Instituts, in Rabat,

Received February 22, 1999; accepted for publication June 25, 1999; electronically published August 9, 1999.

Address for correspondence and reprints: Dr. Ahmed Bouhouche, Laboratoire de Neurogénétique, Service de Neurologie, Hôpital des Spécialités, Rabat-Instituts, Rabat, Morocco. E-mail: abouhouche@hotmail.com

© 1999 by The American Society of Human Genetics. All rights reserved. 0002-9297/1999/6503-0017\$02.00

Morocco. Clinical and electrophysiological examinations were performed on 17 family members, including 9 affected individuals, 5 at-risk relatives, and 3 parents (fig. 1). Individuals were considered to be affected when they presented, at least in the lower limbs, with signs of motor and sensory neuropathy and abnormal electrophysiological findings.

Genotyping

Blood samples from the 17 individuals were obtained after informed consent was given, and genomic DNA was extracted, by use of standard procedures, in the Laboratoire de Neurogénétique of the Hôpital des Spécialités, Rabats-Instituts, in Rabat. For the genomewide search, the ABI PRISM linkage-mapping set version 2 (Perkin-Elmer/Applied Biosystems) was used. The set consists of 400 fluorescent microsatellite markers, selected from the Génethon human linkage map (Weissenbach et al. 1992; Gyapay et al. 1994; Dib et al. 1996), that cover the entire human genome, with a resolution of ~10 cM (Schuster et al. 1996). The markers were amplified by PCR performed with the following conditions: 60 ng genomic DNA, 5 pmol each primer, 2.5 mM of each dNTP, 1.5 µl 10 × PCR buffer II, and 0.6 U AmpliTaq Gold DNA polymerase, in a final volume of 15 µl. Samples were incubated in a thermocycler for 12 min at 95°C to initiate activation of the AmpliTaq Gold DNA polymerase; for 15 s at 94°C, 15 s at 55°C, and 30 s at 72°C for 10 cycles; for 15 s at 89°C, 15 s at 55°C, and 30 s at 72°C, for 25 additional cycles; and, for a final extension, for 10 min at 72°C. After amplification, PCR products were pooled, combined in a tube with GeneScan 400HD size standard, and loaded onto a 4% acrylamide gel by use of the ABI PRISM 377 DNA Sequencer (Perkin-Elmer). CEPH 1347-02 DNA was used as a control.

Linkage Analysis

Pairwise and multipoint LOD scores were calculated by use of the MLINK and LINKMAP programs of the FASTLINK package (Schäffer et al. 1994); a fully penetrant autosomal recessive trait with a disease-allele frequency of .0001 and an equal recombination fraction in males and females was assumed. We assigned equal frequencies to the alleles observed in the family studied. At-risk individuals 44, 48, and 61—who were clinically and electrophysiologically normal at age 35, 42, and 48 years, respectively—were considered to be unaffected; however, the status of individuals 58 and 59, who had no clinical and electrophysiological signs, was considered to be unknown because of their age—13 and 18 years, respectively—at examination. Haplotypes were constructed according to the principles of Thompson

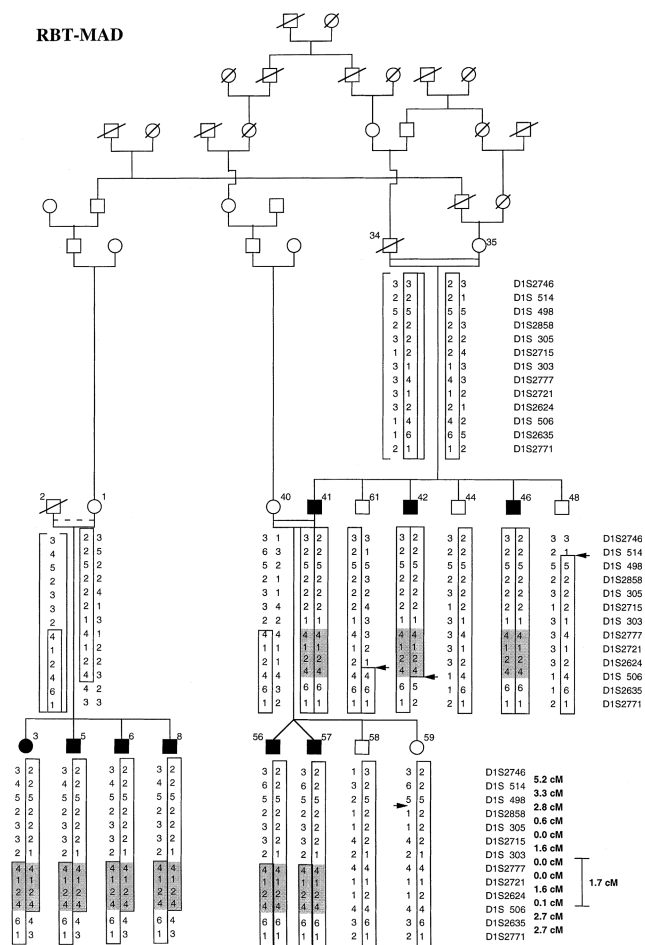

Figure 1 Haplotype reconstruction for chromosome 1q markers in a Moroccan family with ARCMT2. The consanguinity loop between individuals 1 and 2 could not be precisely characterized and is represented by a dashed line. Deduced haplotypes for individuals 2 and 34 are bracketed. Microsatellite markers are ordered, according to the Génethon genetic map, from centromere (top) to telomere (bottom). The hatched area represents the common region of homozygosity for all affected individuals. Observed recombinations are indicated by arrows.

(1987). The order of the markers was that of the consensus CEPH/Génethon chromosome 1 linkage map of the Genome Database (fig. 1).

Physical Mapping of the P0 Locus

The P0 primers used to screen the CEPH YAC library and YAC DNA were as follows: CCT GAC TAC ATT GTC CTC CC (forward primer, intron 2) and CTG GAT GCG CTC TTT GAA GGA (reverse primer, exon 3). Primers for D1S2635, D1S2771, D1S2675, and D1S2705 were the same as those previously described by Dib et al. (1996). Total yeast DNA was extracted by the means described by Blanchard and Nowotny (1994). PCR amplification was performed

in 50 μ l containing 5 μ l 10 \times PCR buffer, 10 pmol of each dNTP, 20 pmol of each primer, 300 ng yeast genomic DNA, and 1.5 μ l *Taq* DNA polymerase (Promega). After an initial cycle of 5 min at 95°C, 30 cycles of amplification were performed for 1 min at 95°C, 1 min at 52°C (for all primers except P0 at 60°C), and 1 min at 72°C. The reaction was completed by a terminal elongation step for 7 min at 72°C. PCR products were visualized, under UV light, after electrophoresis in 1.5% agarose gel.

Sequencing

Exons 1-5 and the coding part of exon 6 of the P0 gene were amplified by PCR using primers described by Hayasaka et al. (1993) and using the standard procedure done in patient 41 (fig. 1). Samples were purified by use of the QIAquick PCR Purification Kit (QIAGEN). They were then sequenced on both strands and were analyzed by use of The Big DyeTM Terminator Cycle Sequencing Ready Reaction Kit (Applied Biosystems) and the ABI PRISM 377 DNA Sequencer (Perkin-Elmer).

Results

Clinical and Electrophysiological Findings

Age at onset of the disease was in the 2d decade (10-18 years) in all nine patients. The age at examination was 15-49 years. All patients presented with weakness and wasting of the distal limb muscles and had areflexia predominantly in the lower limbs. Pes cavus were present in seven cases. Of the six patients who had evident involvement of the proximal muscles, three had muscle weakness and wasting of both limb girdles, which are associated with severe kyphoscoliosis. The neuropathy was severe and was responsible for loss of autonomy in five cases.

Motor-nerve conduction velocity was normal or slightly reduced in all patients: mean motor-nerve conduction velocities were 53 \pm 9.2 m/s for the median nerve, 50.1 \pm 8.8 m/s for the ulnar nerve, and 39.2 \pm 6.5 m/s for the peroneal nerve. Sensory-nerve action potentials were decreased or absent in all patients. These electrophysiological data reflected an axonal-disorder process. A superficial peroneal-nerve biopsy performed in patient 56 (fig. 1) confirmed the presence of axonal neuropathy with an important loss of large myelinating fibers and few clusters of regeneration. The detailed clinical, electrophysiological, and neuropathological findings will be reported elsewhere (Birouk et al., unpublished data).

Linkage Analysis

To exclude candidate loci, we first performed a two-point linkage study of the parents and affected individ-

uals to determine the four loci responsible for autosomal recessive demyelinating CMT on 8q13-21.1 (Ben Othmane et al. 1993), 11q23 (Bolino et al. 1996), 5q23-33 (LeGuern et al. 1996), and 8q24 (Kalaydjieva et al. 1996); and to determine the three loci responsible for autosomal dominant axonal CMT on 3q13-22 (Kwon et al. 1995), 7p14 (Ionasescu et al. 1996), and 1p35-36 (Saito et al. 1997). Negative LOD scores were obtained for all these loci (data not shown).

A genomewide search was conducted on the affected individuals and their parents. After genotyping ~25% of the autosomal genome, homozygosity was observed with marker D1S498 in all patients (fig. 1). Pairwise LOD-score analysis at this locus generated a positive value of 2.23 at recombination fraction (θ) 0 (table 1), which suggested linkage between the disease and marker D1S498. Linkage analysis was extended to 12 markers covering 21 cM in this region. LOD scores above the threshold of +3 at θ = 0 were observed for the D1S514, D1S2715, D1S2777, and D1S2721 markers (table 1). For D1S303, D1S2777, D1S2721, and D1S2624, the multipoint LOD score reached the value of 6.10 (fig. 2).

According to the Généthon map, haplotype reconstruction revealed that all patients shared a common 4.4-cM region of homozygosity, encompassing the D1S2777, D1S2721, D1S2624, and D1S506 markers. The centromeric boundary of this interval corresponded to an inferred recombination between D1S2777 and D1S303, which was observed in individuals 3, 5, 6, 8, 56, and 57 and which probably occurred in a common ancestor of individuals 2 and 40. This shows that D1S303 is centromeric to D1S2777, although these markers are placed at the same locus on the Généthon

Table 1

Pairwise LOD Scores for 16 Chromosome 1q Markers

MARKER ^a	LOD SCORE AT θ =						
	.00	.01	.05	.10	.20	.30	.40
D1S2746	1.88	1.83	1.65	1.41	.91	.45	.12
D1S514	3.00	2.95	2.70	2.36	1.62	.89	.28
D1S498	2.23	2.17	1.96	1.69	1.15	.63	.21
D1S2858	1.43	1.39	1.22	1.02	.64	.31	.08
D1S305	2.81	2.75	2.49	2.16	1.48	.83	.28
D1S2715	3.83	3.73	3.34	4.86	1.91	1.01	.30
D1S303	2.95	2.87	2.57	2.21	1.49	.81	.25
D1S2777	3.13	3.05	2.74	2.35	1.59	.87	.27
D1S2721	3.34	3.26	2.92	2.50	1.67	.89	.26
D1S2624	2.71	2.63	2.33	1.96	1.25	.62	.17
D1S506	∞	1.73	2.09	1.96	1.41	.78	.24
D1S2635	∞	.62	1.64	1.78	1.44	.86	.28
D1S2771	∞	-1.65	-.45	.07	.11	.08	.02
D1S2675	∞	-4.50	-1.92	-.97	-.28	-.06	-.01
D1S2705	∞	-2.09	-.27	.29	.50	.35	.13
D1S2768	∞	-1.35	-.08	.30	.38	.23	.06

^a Ordered from centromere (top) to telomere (bottom).

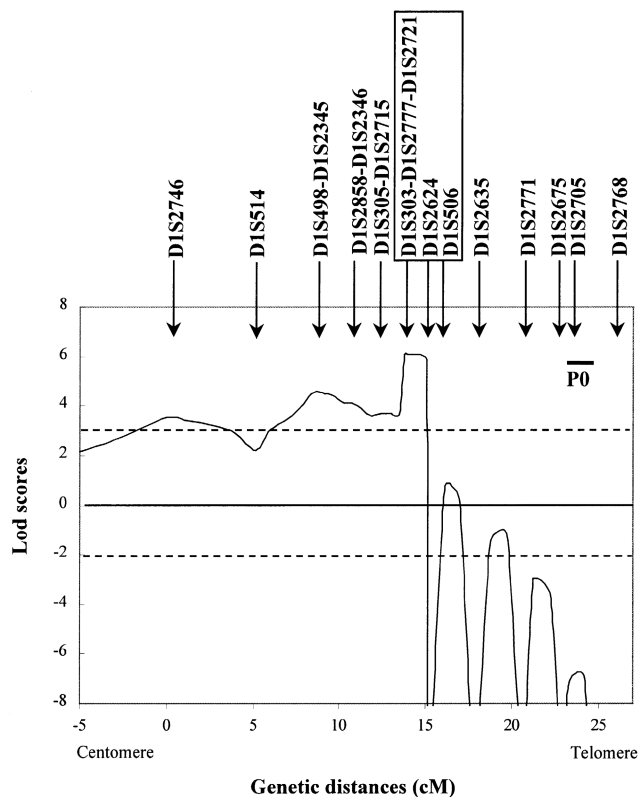

Figure 2 Multipoint linkage analysis in a Moroccan family with ARCMT2. The genetic distances are represented as on the Génethon chromosome 1 map. Horizontal dashed lines indicate the limit of exclusion (LOD score = -2) and the limit of significant linkage (LOD score = +3). Markers of the region of homozygosity are boxed. The interval containing P0 is indicated by the thicker unbroken line.

map. The telomeric boundary of the region of homozygosity is delimited by the inferred recombination between D1S506 and D1S2635, which was observed in patients 3, 5, 6, and 8 and in their unaffected mother. This limit is supported by the recombination event detected in patient 42, which placed the gene centromeric to D1S2635. Moreover, in at-risk individual 61, who can be considered to be normal because he is asymptomatic at age 48 years, the recombination between D1S2624 and D1S506 reduced the candidate interval to a 1.7-cM region.

Physical Mapping and Sequencing of the P0 Gene

Since the receptor of the Fc fragment of immunoglobulin type II (FcγRII), which physically colocalized with the P0 gene within a 130-kb region (Pham-Dinh et al. 1993), was telomeric to D1S2635 in the National Center for Biotechnology Information GeneMap'98, the CEPH YAC library was screened by PCR with P0-specific primers. Amplification signals were obtained for

YACs 777D5 and 884D9. Both YACs were tested with markers D1S2635, D1S2771, D1S2675, and D1S2705. P0 was colocalized with D1S2675 and D1S2705 on YAC 884D9, but only with D1S2705 on YAC 777D5. No signal was obtained for D1S2635 and D1S2771 (table 2). No mutations were revealed by direct DNA sequencing of exons 1–5 and the 5' portion of exon 6 of the P0 gene corresponding to the entire coding region in affected individual 41.

Discussion

This study of a large consanguineous Moroccan family has resulted in the identification of the first locus for ARCMT2 on the long arm of chromosome 1. The patients presented with classic clinical signs of CMT, but, in addition, the majority of patients also had pronounced impairment of the proximal limb muscles. Even though onset of CMT is in the 2d decade, by that time neuropathy is already very severe, with four individuals being dependent on a wheelchair. The electrophysiological and neuropathological data indicated that the disease was axonal CMT.

In all patients, homozygosity for markers D1S2777, D1S2721, D1S2624, and D1S506, as well as significant positive LOD scores for D1S2777 and D1S2721, localized the ARCMT2 gene within a 4.4-cM interval on chromosome 1q21.2-21.3. The recombination event in unaffected individual 61, who is 20 years older than the family member with latest onset of the disease, further reduced the candidate interval, to the 1.7-cM region between markers D1S303 and D1S506.

Physical mapping clearly showed that P0, which is responsible for CMT1B, is telomeric to the candidate genetic interval (D1S303–D1S506) defined by multipoint LOD-score analysis (fig. 2). The genetic distance between D1S506 and D1S2705, which colocalizes with the P0 gene, is ~8 cM. Furthermore, multipoint analysis excluded the region between D1S2771 and D1S2768, which contains the P0 locus (fig. 2). Since no mutations were found in the coding region of the P0 gene, which

Table 2

PCR Amplification of YAC DNA with Primers for Markers of the 1q21-q23 Region and for the P0 Gene

MARKER	YAC ^a	
	777D5	884D9
D1S2635	-	-
D1S2771	-	-
D1S2675	-	+
D1S2705	+	+
P0	+	+

^a A plus sign (+) denotes presence of amplification, and a minus sign (-) denotes absence of amplification.

was analyzed in individual 41, mutation of the P0 gene cannot be responsible for ARCMT2.

The connexin 40 (Cx40) and connexin 50 (Cx50) genes located on chromosome 1q were also potential candidates, since mutations in the connexin 32 gene are responsible for X-linked CMT (Bergoffen et al. 1993). By physical mapping, the Cx40 gene, which encodes the GJA5 protein and is responsible for cardiac-impulse conduction (Kanter et al. 1994), was localized between markers D1S2612 and D1S498 (Gelb et al. 1997), which are 5 cM telomeric to the candidate interval. The Cx50 gene, which codes for the intrinsic lens-membrane protein MP70 and is responsible for zonular pulverulent cataract (MIM 116200), is also outside the locus, since it has been mapped to chromosome 1q21.1 by FISH (Geyer et al. 1997). The responsible gene has yet to be identified. Analysis of additional families with ARCMT2 will help to refine the candidate region, evaluate the relative frequency of the chromosome 1q locus, and test for further genetic heterogeneity.

Acknowledgments

We wish to thank Drs. Dominique Hillaire and Olivier Didierjean for their technical help and Dr. Merle Ruberg for her critical reading of the manuscript. This work was supported by grants from the Association Marocaine de Neurogénétique (AMNG), from the Association Française contre les Myopathies (AFM), from the Assistance Publique des Hôpitaux de Paris, and from les Hospices Civils de Lyon. INSERM U.289 (Paris) and the Laboratoire de Génétique Moléculaire Humaine, Lyon, are members of the European CMT Consortium sponsored by EU Biomed 2 grants CT 961614 and CT 960055.

Electronic-Database Information

Accession numbers and URLs for data in this article are as follows:

Centre d'étude du Polymorphisme Humain, <http://www.cephb.fr>
 GeneMap'98, <http://www.ncbi.nlm.nih.gov/genemap98>
 Généthon, <http://www.genethon.fr>
 Genome Database, <http://www.gdb.org>
 Online Mendelian Inheritance in Man (OMIM), <http://www.ncbi.nlm.nih.gov/Omim> (for CMT [MIM 118200] and zonular pulverulent cataract [MIM 116200])

References

Ben Othmane K, Hentati F, Lennon F, Ben Hamida C, Blel S, Roses AD, Pericak-Vance MA, et al (1993) Linkage of a locus (CMT4A) for autosomal recessive Charcot-Marie-Tooth disease to chromosome 8q. *Hum Mol Genet* 2: 1625-1628
 Bergoffen J, Scherer SS, Wang S, Scott MO, Bone LJ, Paul DL, Chen K, et al (1993) Connexin mutations in X-linked Charcot-Marie-Tooth disease. *Science* 262:2039-2042
 Blanchard M, Nowotny V (1994) High-throughput rapid yeast

DNA extraction: application to yeast artificial chromosomes as polymerase chain reaction template. *Genet Anal Tech Appl* 11:7-11

Bolino A, Brancolini V, Bono F, Bruni A, Gambardella A, Romeo G, Quattrone A, et al (1996) Localization of a gene responsible for autosomal recessive demyelinating neuropathy with focally folded myelin sheaths to chromosome 11q23 by homozygosity mapping and haplotype sharing. *Hum Mol Genet* 5:1051-1054

Dib C, Faure S, Fizames C, Samson D, Drovot N, Vignal A, Millasseau P, et al (1996) A comprehensive genetic map of the human genome based on 5,264 microsatellites. *Nature* 380:152-154

Gabreëls-Festen AAWM, Gabreëls FJM, Jennekens FGI (1993) Hereditary motor and sensory neuropathies: present status of type I, II, and III. *Clin Neurol Neurosurg* 95:93-107

Gabreëls-Festen AAWM, Joosten EMG, Gabreëls FJM, Jennekens FGI, Gooskens RHJM, Stegeman DF (1991) Hereditary motor and sensory neuropathy of neuronal type with onset in early childhood. *Brain* 114:1855-1870

Gelb BD, Zhang J, Cotter PD, Gershin IF, Desnick RJ (1997) Physical mapping of the human connexin 40 (GJA5), flavin-containing monooxygenase 5, and natriuretic peptide receptor A genes on 1q21. *Genomics* 39:409-411

Geyer DD, Church RL, Steele EC Jr, Heinzmann C, Kojis TL, Klisak I, Sparkes RS, et al (1997) Regional mapping of the human MP70 (Cx50; connexin 50) gene by fluorescence in situ hybridization to 1q21.1. *Mol Vis* 3:13

Gyapay G, Morissette J, Vignal A, Dib C, Fizames C, Millasseau P, Marc S, et al (1994) The 1993-94 Généthon human genetic linkage map. *Nat Genet* 7:246-339

Harding AE, Thomas PK (1980) Autosomal recessive forms of hereditary motor and sensory neuropathy. *J Neurol Neurosurg Psychiatry* 43:669-678

Hayasaka K, Himoro M, Sato W, Takada G, Uyemura K, Shimizu N, Bird T, et al (1993) Charcot-Marie-Tooth neuropathy type 1B is associated with mutations of the myelin P0 gene. *Nat Genet* 5:31-34

Ionasescu V, Searby C, Sheffield VC, Roklina T, Nishimura D, Ionasescu R (1996) Autosomal dominant Charcot-Marie-Tooth axonal neuropathy mapped on chromosome 7p (CMT2D). *Hum Mol Genet* 5:1373-1375

Kalaydjieva L, Hallmayer J, Chandler D, Savov A, Nikolova A, Angelicheva D, King RH, et al (1996) Gene mapping in Gypsies identifies a novel demyelinating neuropathy on chromosome 8q24. *Nat Genet* 14:214-217

Kanter HL, Saffitz JE, Beyer EC (1994) Molecular cloning of two human cardiac gap junction proteins, connexin 40 and connexin 45. *J Mol Cell Cardiol* 26:861-868

Kwon JM, Elliott JL, Yee WC, Ivanovich J, Scavarda NJ, Moolsintong PJ, Goodfellow PJ (1995) Assignment of a second Charcot-Marie-Tooth type II locus to chromosome 3q. *Am J Hum Genet* 57:853-858

Le Guern E, Guilbot A, Kessali M, Ravisé N, Tassin J, Maissonobe T, Grid D, et al (1996) Homozygosity mapping of an autosomal recessive form of demyelinating Charcot-Marie-Tooth disease to chromosome 5q23-q33. *Hum Mol Genet* 5:1685-1688

Ouvrier RA, McLeod JG, Morgan GJ, Wise GA, Conchin TE (1981) Hereditary motor and sensory neuropathy of neu-

- ronal type with onset in early childhood. *J Neurol Sci* 51: 181-197
- Pham-Dinh D, Fourbil Y, Blanquet F, Mattéi MG, Roeckel N, Latour P, Chazot G, et al (1993) The major peripheral myelin protein zero gene: structure and localization in the cluster of Fcγ receptor genes on human chromosome 1q21.3-q23. *Hum Mol Genet* 2:2051-2054
- Saito M, Hayachi Y, Suzuki T, Tanaka H, Hozumi I, Tsuji S (1997) Linkage mapping of the gene for Charcot-Marie-Tooth disease type 2 to chromosome 1p (CMT2A) and the clinical features of (CMT2A). *Neurology* 49:1630-1635
- Schäffer AA, Gupa SK, Shriram K, Cottingham RW Jr (1994) Avoiding recomputation in genetic linkage analysis. *Hum Hered* 44:225-237
- Schuster H, Wienker TE, Bähring S, Bilginturan N, Toka HR, Neitzel H, Jeschke E, et al (1996) Severe autosomal dominant hypertension and brachydactyly in a unique Turkish kindred maps to human chromosome 12. *Nat Genet* 13: 98-100
- Thompson EA (1987) Crossover counts and likelihood linkage analysis. *IMA J Math Appl Med Biol* 4:93-108
- Weissenbach J, Gyapay G, Dib C, Vignal H, Morissette J, Millasseau P, Vaysseix G, et al (1992) A second-generation linkage map of the human genome. *Nature* 359:794-801